

STAR 90 SERIES 800MM WIDE
GAS RADIANT BBQ GRILL

Gas grill constructed in AISI 304 stainless steel. Reversible cast iron cooking grill. Forward sloping for cooking fatty meats, with 40 mm elements in direct contact and drip tray for collecting grease. Flat for cooking fish and vegetables with circular 10 mm diameter elements. 135 mm tall splashguard in AISI 304 stainless steel on three sides.

Grease collection channel at front, easily removed for cleaning. Removable drawer for collecting cooking fats or holding water, positioned underneath the heating elements. The water allows the cooking fats to cool. Evaporation of water ensures grilled food will be tender. Controls positioned on fixed front control panel.

Heating by means of burner in AISI 304 stainless steel positioned under the grill, protected by the AISI 316 stainless steel diffuser, easily removed for cleaning. Heat is adjusted by means of a safety tap with thermocouple and a pilot burner. Piezoelectric ignition. Scraper for grill supplied. Appliance equipped with height adjustable feet in stainless steel (850-900 mm). IPX5 protection rating.

STANDARD FEATURES

- 2 mm thick pressed stainless tops
- IPX5 water protection
- Modular design
- Interlocking device supplied with all units
- Space at rear for connections
- Flame failure and standing pilot light
- Natural to Propane gas conversion kit
- External gas regulator supplied (specify gas type)
- Scraper for grill supplied

OPTIONAL FEATURES

- Castor kit
- Flexible gas hose with quick disconnect



DIMENSIONS
900D x 800W x 870H mm
Plate Dimensions: 632 x 627
TECHNICAL DATA
Gas Type: Natural or Propane
Total Output (Gas): Natural Gas - 82MJ/h Propane Gas - 79.2MJ/h
Gas Connection: 1/2"
AGA approval number: 7416
SHIPPING DATA
Net Weight: 104kg
Shipping Weight: 118kg
Shipping Dimensions: 840W x 1020L x 1100H mm

SPECIFICATIONS ARE SUBJECT TO CHANGE WITHOUT NOTICE.

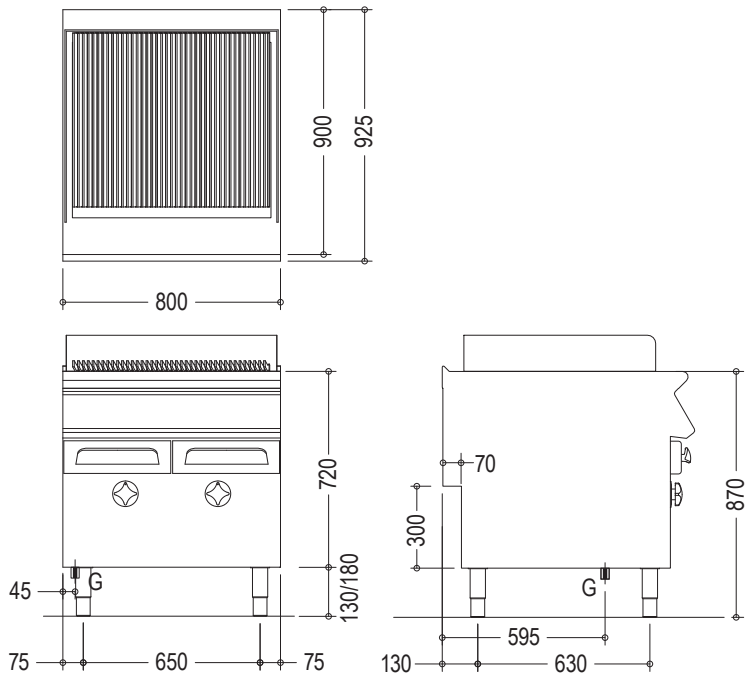

LEGEND

G = Gas - 1/2"