

GARLAND MST B SERIES

MASTER SERIES CHAR BROILER

Master Series Char-broiler with stainless steel front & black power coat sides. Broiling area consists of heavy duty rack sections which are easily moved for flat or tilt position broiling. Dual sided, cast iron broiler grates with 13mm rounded bar, (board brand) and diamond (fine) pattern on opposite side. Sentry total flame failure protection for all burners Large capacity full length grease drawers. Heavy-weight, long lasting briquettes. Cabinet, 432mm, 610mm, or 864mm, wide by 869mm deep, with stainless steel full-sized hinged doors and front. Natural gas or propane.



STANDARD FEATURES

- Stainless steel front doors
- Stainless steel front rail
- Piezo spark ignition with constant burning pilots
- Storage base interior of aluminized steel
- Electric Spark ignition on all pilots Suffix - E models
- Sentry total flame failure protection for all burners
- Dual sided, cast iron broiler grates with 13mm rounded bar, (board brand) and diamond (fine) pattern on opposite sides
- Stainless steel front & black powder coat sides
- 1-1/4" NPT front manifold
- 15.8mj burners,
- 152mm chromed steel adjustable legs

OPTIONAL FEATURES

- Stainless steel left, right, or both sides; main back
- Gas regulator 3/4" or 1-1/4"
- End caps and cover (NC, specify)
- Dais base
- Rear gas connection; 3/4" NPT
- Gas flex hose & quick disconnect
- 152mm stainless steel adjustable legs
- Swivel casters (4) w/front brakes

SPECIFICATIONS ARE SUBJECT TO CHANGE WITHOUT NOTICE.

From the world of Comcater!

National Head Office
156 Swann Drive
Derrimut VIC 3030
Tel: +61 3 8369 4600
Fax: +61 3 8369 4695

Melbourne
96-100 Tope Street,
South Melbourne VIC 3205
Tel: +61 3 8369 4600
Fax: +61 2 8699 1299

Sydney
20/4 Avenue of the Americas
Newington, NSW 2127
Tel: +61 2 9748 3000
Fax: +61 2 9 648 4762

Brisbane
1/62 Borthwick Avenue
Murarrie QLD 4172
Tel: +61 7 3399 3122
Fax: +61 7 3399 5311

GARLAND MST B SERIES

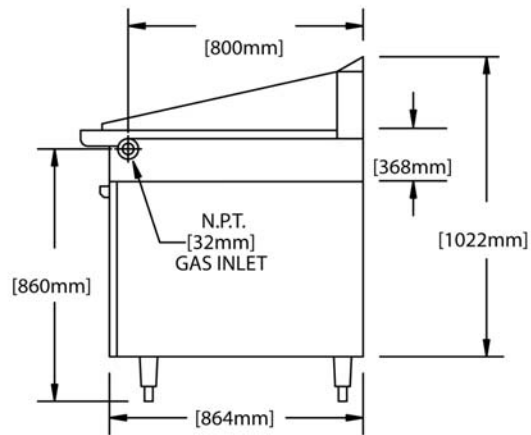
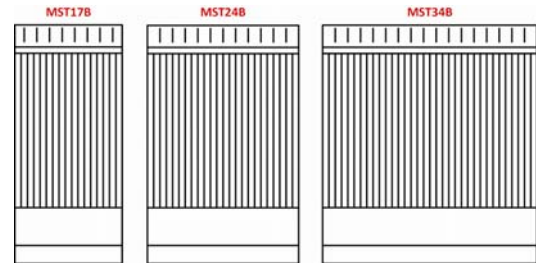
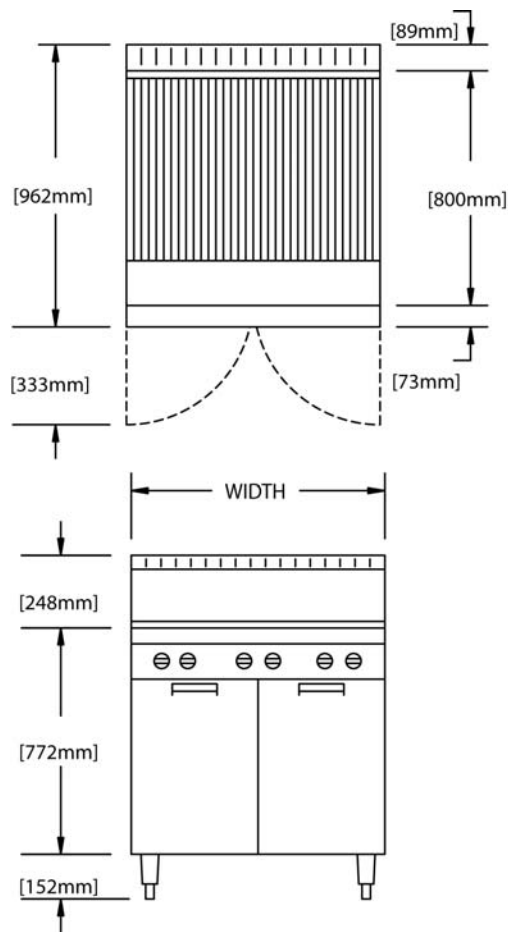

DIMENSIONS

Dimension:

432W x 965D x 924H mm (MST17B)

612W x 965D x 924H mm (MST24B)

864W x 965D x 924H mm (MST34B)

TECHNICAL DATA

Gas Type Natural or LP

Total Energy Rating 47mj (MST17B)

63mj (MST24B)

94mj (MST34B)

AGA Approval Number SC384

SPECIFICATIONS ARE SUBJECT TO CHANGE WITHOUT NOTICE.