

GARLAND GF60 SERIES

10 BURNER RANGE WITH 2 LARGE OVENS

Gas restaurant series range with 2 x large capacity (standard) ovens. 1500mm wide and 686mm deep work top surfaces. Total flame failure protection for all burners. Stainless steel front, sides and 127mm wide front rail. 152mm legs with adjustable feet. Ten Starfire-Pro 2 piece, 27mJ cast open burners set in split cast iron ergonomic grates. Griddle or optional hot top with cast iron "H" style burners. Porcelain oven interior with ribbed oven bottom and door. "Keep cool" oven door handle. Heavy cast iron "H" 40mJ (natural gas) oven burners controlled by even bake, fast recovery snap action modulating oven thermostat. Available with convection or standard oven bases.



STANDARD FEATURES

- Spark ignition on all concealed burners (open top burners manual ignition)
- Stainless steel front and sides, stainless steel 127mm plate rail
- 300mm section stamped drip trays w/dimpled bottom
- Flame failure protection: all burners
- Large 686mm work top surface
- Stainless steel low profile back guard
- 152mm adj. stainless steel legs
- Large easy-to-use control knobs
- Gas regulator
- 1" Gas Connection

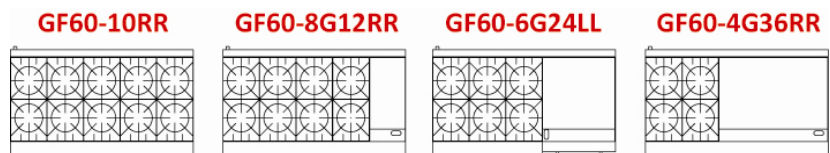

OPTIONAL FEATURES

- Additional oven racks
- Flanged deck mount legs
- Grooved griddle in 1/2 or full plate section widths
- 300mm plate hot top in lieu of 2 open burners, manual valve controlled w/19mJ cast iron "H" style burner standard on left side

SPECIFICATIONS ARE SUBJECT TO CHANGE WITHOUT NOTICE.

From the world of Comcater!

National Head Office
156 Swann Drive
Derrimut VIC 3030
Tel: +61 3 8369 4600
Fax: +61 3 8369 4695

Melbourne
96-100 Tope Street,
South Melbourne VIC 3205
Tel: +61 3 8369 4600
Fax: +61 2 8699 1299

Sydney
20/4 Avenue of the Americas
Newington, NSW 2127
Tel: +61 2 9748 3000
Fax: +61 2 9 648 4762

Brisbane
1/62 Borthwick Avenue
Murarrie QLD 4172
Tel: +61 7 3399 3122
Fax: +61 7 3399 5311

GARLAND GF60 SERIES

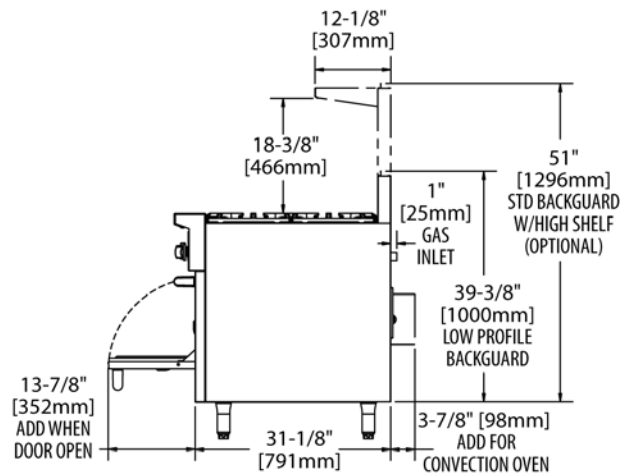
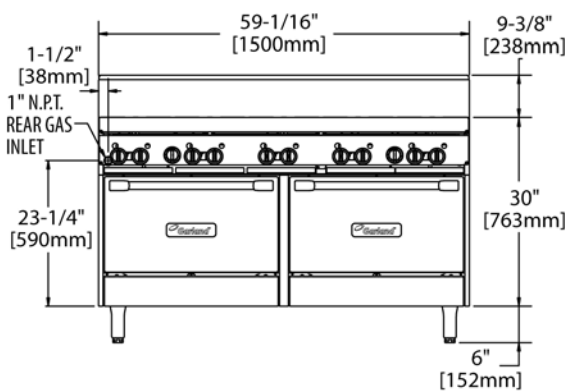
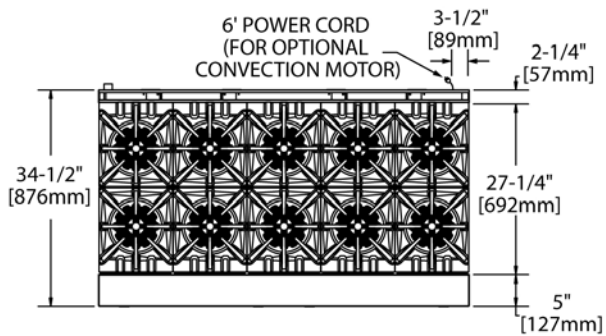

DIMENSIONS

External Dimension: 1500W x 876D x 915H mm

Oven Interior : 667W x 660D x 330H mm (x2)

TECHNICAL DATA

Gas Type	Natural or LP
Total Energy Rating	354mj (GF60-10RR) 318mj (GF60-8G12RR) 283mj (GF60-6G24RR) 247mj (GF48-4G36RR)
Burner Ratings (Natural)	27mj (Open Burner) 19mj (Griddle/Hotplate) 40mj (Oven)
Burner Ratings (LP)	27mj (Open Burner) 19mj (Griddle/Hotplate) 33mj (Oven)
AGA Approval Number	7455

SPECIFICATIONS ARE SUBJECT TO CHANGE WITHOUT NOTICE.